



BRECONCHERRY



Breconcherry Cleaning Technology

Orbital cleaner OC200

Operating instruction (Translation from the original language)

430BAL013918EN_6

COPYRIGHT

These Operating Instructions are the English translation of the original operating instructions in the sense of the EU Machinery Directive. This document is protected by copyright. All rights reserved. The document may not, in whole or in part, be copied, reproduced, translated or reduced to an electronic medium of machine-readable form without the express permission of Breconcherry Ltd.

LEGAL NOTICE

—

TABLE OF CONTENTS

1	General Information	5
1.1	Information on the Document	5
1.1.1	Binding Character of These Operating Instructions	5
1.1.2	Notes on the Illustrations	5
1.1.3	Symbols and Highlighting	5
1.2	Manufacturer address	6
1.3	Contact	6
1.4	EC Declaration of Conformity for Partially Completed Machines	7
2	Safety	8
2.1	Intended use	8
2.1.1	Requirements for operation	8
2.1.2	Improper operating conditions	8
2.2	Operator's Duty of Care	8
2.3	Subsequent changes	9
2.4	General safety instructions and dangers	9
2.4.1	Principles for safe operation	9
2.4.2	Environmental Protection	10
2.5	Supplementary regulations	10
2.6	Qualification of personnel	10
2.7	Residual dangers	12
2.8	Danger zones	13
3	Description	14
3.1	Design	14
3.2	Functional description	15
4	Transport and storage	16
4.1	Storage conditions	16
4.2	Transport	16
4.2.1	Scope of supply	16
5	Technical data	17
5.1	Identification	17
5.2	Orbital cleaner OC 200	17
5.3	Dimensions	18
5.4	Resistance and permitted operating temperature of the sealing materials	20
5.5	Tool	21
5.6	Weights	22
6	Assembly and installation	23
6.1	Safety notes	23
6.2	Notes on installation	23
6.3	Installation	23
6.4	Removing	24
7	Start-up	26
7.1	Safety notes	26
7.2	Commissioning	26
8	Operation and control	27
8.1	Safety notes	27
8.2	Operating Conditions	27
9	Maintenance	30
9.1	Safety notes	30
9.2	Maintenance intervals	31
9.3	Replace stator and impeller	31
9.4	Disassembly	34
9.4.1	Dismantling the rotating (lower) housing	34
9.4.2	Separate static (upper) and rotating (lower) housing	38
9.4.3	Remove individual parts from static (upper) housing (1)	40
9.4.4	Disassembly of the planet gear	44
9.5	Installation	46
9.5.1	Torques of the cleaner components	46
9.5.2	Installing the drive shaft assembly	47
9.5.3	Assemble the planetary gear	48

9.5.4	Installation of the bevel gear in the static (upper) body	52
9.5.5	Assembly static (upper) and rotating (lower) housing	54
9.5.6	Mounting the nozzle carrier	56
9.5.7	Check the assembly	60
10	Alarms	62
10.1	Malfunctions and remedies	62
11	Decommissioning	63
11.1	Safety notes	63
11.2	Disposal	63
11.2.1	General notes	63
12	Spare parts list - orbital cleaner OC200	64
13	Appendix	68
13.1	Lists	68
13.1.1	Abbreviations and terms	68

1 General Information

1.1 Information on the Document

The present Operating Instructions are part of the user information for the product. The Operating Instructions contain all the information you need to transport, install, commission, operate and carry out maintenance for the product.

1.1.1 Binding Character of These Operating Instructions

These Operating Instructions contain the manufacturer's instructions to the operator of the product and to all persons who work on or use the product regarding the procedures to follow.

Carefully read these Operating Instructions before starting any work on or using the product. Your personal safety and the safety of the product can only be ensured if you act as described in the Operating Instructions.

Store the Operating Instructions in such a way that they are accessible to the operator and the operating staff during the entire life cycle of the product. When the location is changed or the product is sold make sure you also provide the Operating Instructions.

1.1.2 Notes on the Illustrations

The illustrations in these Operating Instructions show the product in a simplified form. The actual design of the product can differ from the illustration. For detailed views and dimensions of the product please refer to the design documents.

1.1.3 Symbols and Highlighting

In these Operating Instructions, important information is highlighted by symbols or special formatting. The following examples illustrate the most important types of highlighting.



Danger

Warning: Fatal Injuries

Failure to observe the warning can result in serious damage to health, or even death.

- ▶ The arrow identifies a precautionary measure you have to take to avoid the hazard.



Warning: Explosions

Failure to observe the warning can result in severe explosions.

- ▶ The arrow identifies a precautionary measure you have to take to avoid the hazard.
-

 **Warning!**

Warning: Serious Injuries

Failure to observe the warning can result in serious damage to health.

- ▶ The arrow identifies a precautionary measure you have to take to avoid the hazard.

 **Caution!**

Warning: Injuries

Failure to observe the warning can result in minor or moderate damage to health.

- ▶ The arrow identifies a precautionary measure you have to take to avoid the hazard.

Notice

Warning: Damage to Property

Failure to observe the warning can result in serious damage to the component or in the vicinity of the component.

- ▶ The arrow identifies a precautionary measure you have to take to avoid the hazard.

Carry out the following steps: = Start of a set of instructions.

1. First step in a sequence of operations.
 2. Second step in a sequence of operations.
 - Result of the previous operation.
- The operation is complete, the goal has been achieved.

 **Hint!**

Further useful information.

1.2 Manufacturer address

Breconcherry Ltd.
Westfalia House, Old Wolverton Road
Milton Keynes, MK12 5PY, United Kingdom

1.3 Contact

Tel.:+44 (0)1531 632476
Fax:+44 (0)1531 633839
info@breconcherry.com
<http://www.breconcherry.com>

1.4 EC Declaration of Conformity for Partially Completed Machines

General Information
EC Declaration of Incorporation for Partially Completed Machines

**EC Declaration of Incorporation for Partially Completed Machines in accordance with the
EC Machinery Directive 2006/42/EC, Annex II 1. A**

Manufacturer: Breconcherry Ltd
Old Wolverton Road
Buckinghamshire MK12 5PY
United Kingdom

We declare under our sole responsibility that the partially completed machine

Designation: OC200
Type: Breconcherry Orbital cleaner

conforms with all the relevant provisions of this directive and the following directives:

Relevant EC directives:	2006/42/EC	EC Machinery Directive
Applicable harmonized standards, in particular:	DIN EN ISO 12100	Safety of Machines - General design principles - Risk assessment and risk reduction

Other applied standards and technical specifications: --

Remarks: We herewith declare that this consignment contains the subsequently described - but incomplete - machine and that commissioning is suspended until it is established that the machine in which the machine concerned will be installed conforms to the regulations of the EC-Machine Directive.
We declare that the incomplete machine identified here complies with the "Essential Health and Safety Requirements" defined in Annex I, section 1 and section 2.1. The technical documentation is compiled in accordance with Annex VII, part B. In response to a reasoned request the relevant information will be transmitted to the appropriate national authorities.
This declaration becomes invalid in case of alterations at the machine which have not been agreed with us.

Person authorised for compilation and handover of technical documentation:	CE-Dokumentationsbevollmächtigter Breconcherry Ltd Old Wolverton Road Buckinghamshire MK12 5PY
--	---

Buckinghamshire, 2020-03-04



Barry Dumble
Managing Director

2 Safety

2.1 Intended use

The OC200 orbital cleaner is intended for the cleaning of tanks and vessels. This cleaner was designed for the installation and operation at any angle. Using the device for any other purpose is considered contrary to its designated use.



Hint!

The manufacturer will not accept any liability for damage resulting from any use of the cleaner which is not in accordance with its designated use. The risk is borne solely by the operating company.

2.1.1 Requirements for operation

The prerequisite for reliable and safe operation of the component is proper transportation and storage as well as professional installation and assembly. Operating the unit within the limits of its designated use also involves adhering to the operating, inspection and maintenance instructions.

2.1.2 Improper operating conditions

The operational reliability of the cleaner cannot be ensured under improper operating conditions. Therefore avoid improper operating conditions.

Operating the cleaner is not permitted if

- Persons or objects are in the danger zone.
- Safety devices are not working or were removed.
- Malfunctions have been detected on the cleaner.
- Damage has been detected on the cleaner.
- Maintenance intervals have been exceeded.

2.2 Operator's Duty of Care

In your capacity as operator of the facility you bear a particular responsibility for the proper and safe handling of the cleaner in your facility. Only use the cleaner when it is in perfect condition to prevent danger to persons and property.

These Operating Instructions contain the information you and your staff need for the safe and reliable operation during the entire service life of the cleaner. Be sure to read these Operating Instructions carefully and ensure that the measures described here are observed.

The operator's duty of care includes planning the necessary safety measures and monitoring that these measures are observed. The following principles apply:

- Only allow qualified staff to work on the cleaner.
- The operating company must authorize personnel to carry out the relevant tasks.

- Working areas and the entire environment of the cleaner must be neat and clean.
- Personnel must wear suitable work clothing and personal protective equipment. As the operating company must ensure that work clothing and personal protective equipment are used.
- Inform personnel regarding any properties of the product which might pose a health risk and the preventative measures to be taken.
- Have a qualified first-aid representative on call during the operation. This person must be able to initiate any necessary first-aid measures in case of an emergency.
- Clearly define processes, lines of authority and responsibilities associated with the cleaner. Everybody must know what to do in case of an emergency. Instruct the staff in this respect at regular intervals.
- The signs relating to the cleaner must always be complete and legible. Check, clean and replace the signs as necessary at regular intervals.
- Observe the Technical Data specified and the limits of use!



Hint!

Carry out regular checks. This way you can ensure that these measures are actually observed.

2.3 Subsequent changes

You should never make any technical modifications to the cleaner. Otherwise you will have to undergo a new conformity process in accordance with the EC Machinery Directive on your own.

In general, only original Breconcherry spare parts should be fitted. This ensures the reliable and economical operation of the cleaner. Using spare parts from third-party suppliers will invalidate any and all warranty claims.

2.4 General safety instructions and dangers

The cleaner is operationally reliable. It was built according to state-of-the-art science and technology.

Nevertheless, the cleaner can pose dangers, especially if

- the cleaner is not used in accordance with its intended use,
- the cleaner is not used correctly,
- the cleaner is operated under impermissible operating conditions.

2.4.1 Principles for safe operation

Dangerous situations during operation can be avoided by safety-conscious and proactive behaviour of the personnel.

To ensure the safe operation of the cleaner the following principles apply:

- The Operating Instructions must be kept ready to hand and accessible for everyone at the cleaner's place of use. They must be complete and in clearly legible form.
- Only use the cleaner for its intended use.
- The cleaner must be functional and in good working order. Check the condition of the cleaner before starting work and at regular intervals.
- Wear tight-fitting work clothing for all work on the cleaner.
- Ensure that nobody can get hurt on the parts of the cleaner.
- Immediately report any faults or noticeable changes on the cleaner to the person responsible.
- Never touch the pipes and the cleaner when these components are hot! Avoid opening the cleaner, unless the process units have been emptied and depressurised.
- Observe the accident prevention regulations and all local regulations.

2.4.2 Environmental Protection

Harm to the environment can be avoided by safety-conscious and proactive behaviour of the staff.

For environmental protection the following principles apply:

- Substances harmful to the environment must not be discharged into the ground or the sewage system.
- Always observe the pertinent regulations relating to waste avoidance, disposal and utilization.
- Substances harmful to the environment must be collected and stored in suitable containers. Clearly mark the containers.
- Dispose of lubricants as hazardous waste.

2.5 Supplementary regulations

In addition to the instructions in this documentation the following also has to be observed:

- pertinent accident prevention regulations,
- generally accepted safety rules,
- national regulations applicable in the country of use,
- work and safety instructions applicable in the facility,
- installation and operating regulations for use in potentially explosive areas.
- For use in Ex-protected areas, special safety and operating instructions apply. For this purpose, Breconcherry supplies a separate ATEX supplementary operating manual, which must be observed.

2.6 Qualification of personnel

This section contains information about the qualifications that staff working on the cleaner must have.

Operating and maintenance personnel must

- have the necessary qualification to carry out their tasks,
- be instructed with regard to possible dangers,
- know and observe the safety instructions given in the documentation.

Only allow qualified electricians to carry out work on the electrical equipment or have a qualified electrician supervise the work.

Only allow specially trained personnel to carry out work on an explosion-protected system. When working on explosion-protected equipment observe the standards DIN EN 60079-14 for gases and DIN EN 50281-1-2 for dusts.

The following minimum qualifications are required:

- Vocational training as a skilled worker who can work on the cleaner independently.
- Sufficient instruction to work on the cleaner under the supervision and direction of a qualified specialist.

Each member of staff must meet the following requirements to be allowed to work on the cleaner:

- Personal suitability for the respective task.
- Sufficient professional qualification for the respective task.
- Instructed with regard to the function of the cleaner.
- Instructed with regard to the operating sequences of the cleaner.
- Familiar with the safety devices and their function.
- Familiar with these Operating Instructions, especially with the safety instructions and the information which is relevant for the task on hand.
- Familiar with the basic regulations with regard to occupational health and safety and accident prevention.

For work to be carried out on the cleaner the following user groups are distinguished:

User groups	
Staff	Qualifications
Operating personnel	<p>Adequate instruction and sound knowledge in the following areas:</p> <ul style="list-style-type: none"> • Function of the cleaner • Operating sequences of the cleaner • What to do in case of an emergency • Lines of authority and responsibilities with respect to the task
Maintenance personnel	<p>Adequate instruction as well as sound knowledge of the design and function of the cleaner. Sound knowledge in the following areas:</p> <ul style="list-style-type: none"> • Mechanical equipment • Electrical equipment • Pneumatic system <p>Authorization with regard to safety engineering standards to carry out the following tasks:</p> <ul style="list-style-type: none"> • Setting devices into operation • Earthing of devices • Marking of devices <p>The relevant certificates of qualification must be submitted before work can be carried out on ATEX certified machines.</p>

2.7 Residual dangers

Dangerous situations can be avoided by safety-conscious and proactive behaviour of the personnel and by wearing personal protective equipment.

Residual dangers on the cleaner and measures		
Danger	Cause	Measure
Danger to life	Inadvertent switch-on of the cleaner	Effectively disconnect all components, effectively prevent switch-on.
Risk of injury	Danger presented by moving or sharp-edged parts	<p>The operator must exercise caution and prudence. For all work:</p> <ul style="list-style-type: none"> • Wear suitable work clothing. • Never operate the machine if the cover panels are not correctly fitted. • Never open the cover panels during the operation. • Never reach into openings. <p>As a precautionary measure, wear personal protective equipment in the vicinity of the cleaner:</p> <ul style="list-style-type: none"> • Protective gloves • Safety shoes

2.8 Danger zones

Transport, installation

Do not set the cleaner down on the rotating (lower) housing. Store the cleaner in horizontal position and secure it against rolling away to the side.

Commissioning

Please observe the following notes:

- When installing the cleaner, secure it against tipping and twisting and secure all fixing points correctly.
- Only set the cleaner into operation in closed vessels.

Operation

Please observe the following notes:

- Provide suitable protective measures to ensure that the cleaner cannot be set into operation outside of the vessel.
- In the event of faults, stop all media supplies immediately.
- Check the installation situation to ensure that the cleaner is not in contact with other parts and that rotation cannot be obstructed.
- Do not allow the maximum cleaning pressure and the maximum cleaning temperature to be exceeded.
- Vessels, tanks and road tankers etc. must be grounded by suitable means.

Maintenance

Please observe the following notes:

- Close all media supply lines and ensure that no hot or aggressive media are applied to or are in the cleaner.
- Never set the cleaner down on the rotating housing.
- Do not attempt to turn the nozzles by hand.
- Do not use the rotating housing as a tool contact point for installation or removal.

3 Description

3.1 Design

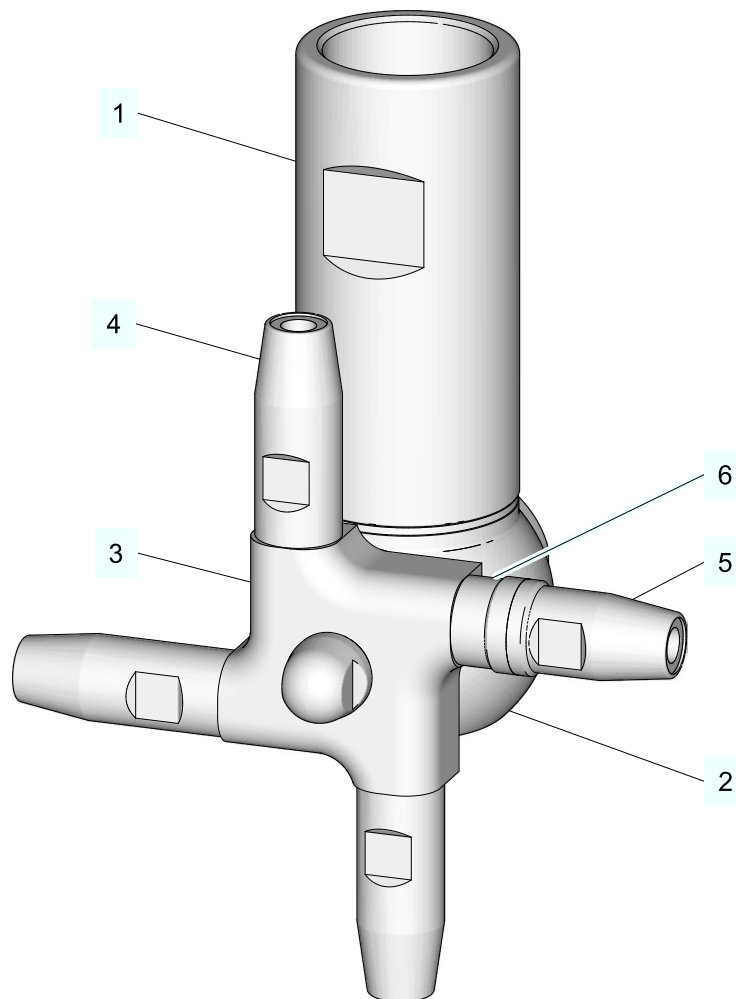

Fig.1

Design	
No.	Designation
1	Static (upper) housing
2	Rotating (lower) housing
3	Nozzle carrier
4	Nozzle
5	Self-cleaning nozzle
6	Nozzle sleeve

3.2 Functional description

The principle of operation of the Orbital Cleaner is based on two horizontally and vertically rotating axes, as shown in the following diagram.

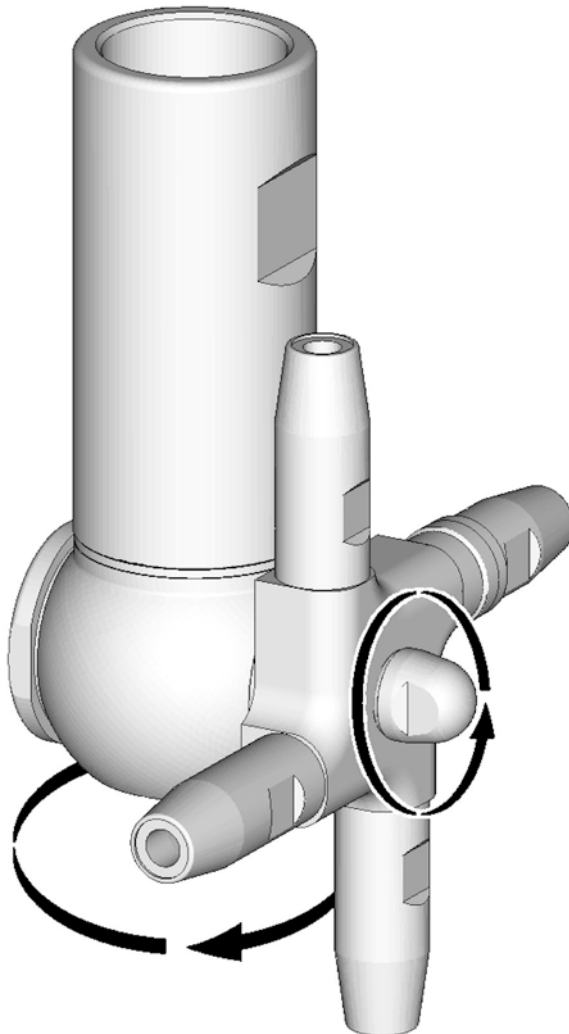

Fig.2

- Hygienic design
- No ball bearings
- Slim, compact construction
- Intensive cleaning through directed streams
- Long service life
- Maintenance friendly
- Drive happens through the cleaning medium
- Low number of components (same spare parts for orbital cleaner Typhoon, Tempest, Tornado)

4 Transport and storage

4.1 Storage conditions

Store the cleaner in a dry place and ensure it is not subjected to vibration and is protected from external influence.

Storage temperature +5...+40 °C

4.2 Transport

For transport, the following principles apply:

- Only use suitable lifting gear and slings for transporting package units/cleaners.
- Observe the pictograms on the package.
- Handle the cleaner with care to avoid damage caused by impact or careless loading and unloading. The outside synthetic materials are susceptible to breaking.
- Only allow qualified staff to transport the cleaner.
- Movable parts must be properly secured.
- Only use approved, fully functional load lifting devices and lifting accessories which are suitable for the intended purpose. Observe the maximum load-bearing capacities.
- Under no circumstances should anyone stand under a suspended load.
- Take care when transporting the cleaner. Do not grip sensitive parts of the unit to lift or push the unit or to support yourself. Avoid jerky movements when putting down the unit.
- Do not set the orbital cleaner down on the rotating (lower) housing. Store the orbital cleaner in the horizontal position and secure the cleaner against rolling away to the side.

4.2.1 Scope of supply

On receipt of the cleaner, check whether

- the details on the type plate correspond to the data in the order and delivery documents,
- the equipment is complete and all components are in good order.

5 Technical data

5.1 Identification

The marking on the cleaner is used for the clear identification of the cleaner.



Hint!

The cleaner is not intended for use in potentially explosive atmospheres.

The label contains the following characteristics:

Characteristics of the cleaner	
Logo	
Type code	e.g. OC200-0-4x9-S-J-OPT-40-BSP-2"-11-10-1-2 //A //ZK
Serial number	for example, SN 1473236-0040-001

5.2 Orbital cleaner OC 200

Technical data – OC 200	
Designation	Description
Standard materials	Stainless steel 316L (1.4404), PEEK, C-PTFE, Iglidur-A350 or Iglidur-H370, EPDM or FKM
Standard connection	Female thread: 2" BSP, 2"NPT
Operating temperature	max. 95° C (203° F)
Ambient temperature	max. 140° C (284° F), max. 30 min for Iglidur-A350
	max. 100°C (212 °F) for Iglidur H370
Operating pressure range	4 - 10 bar (58 - 145 psi)

5.3 Dimensions

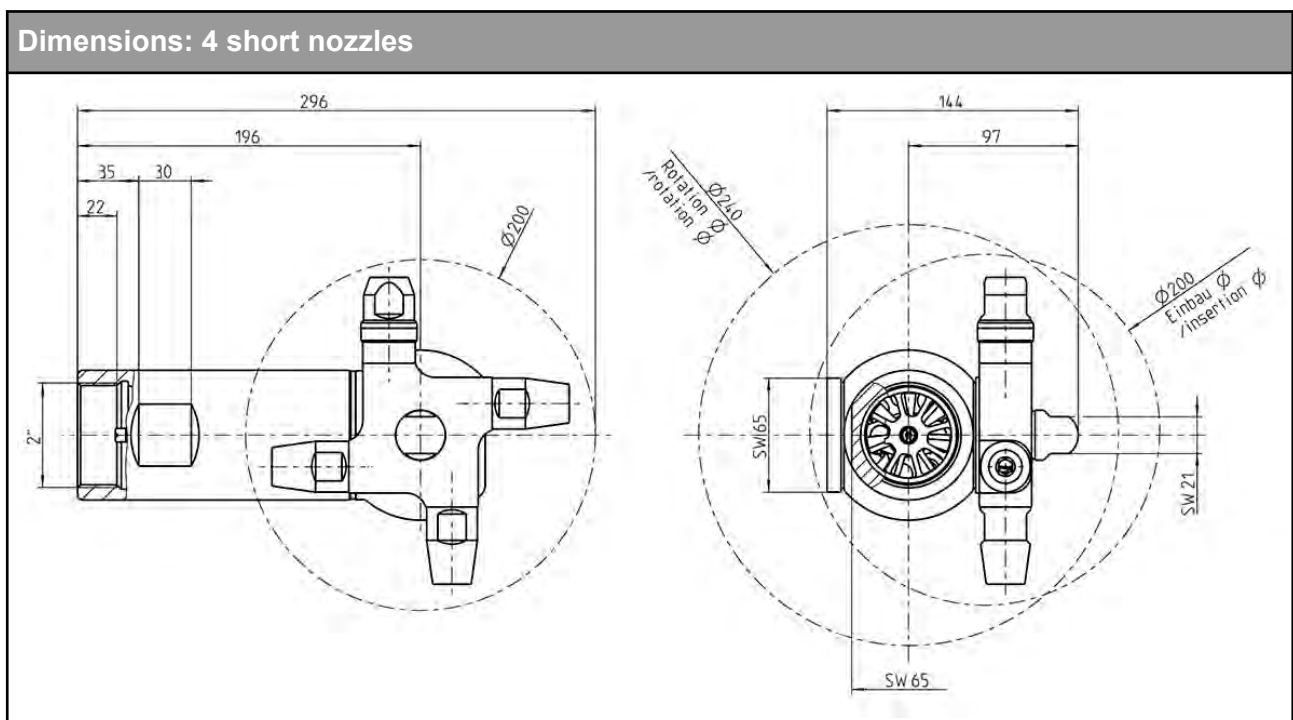
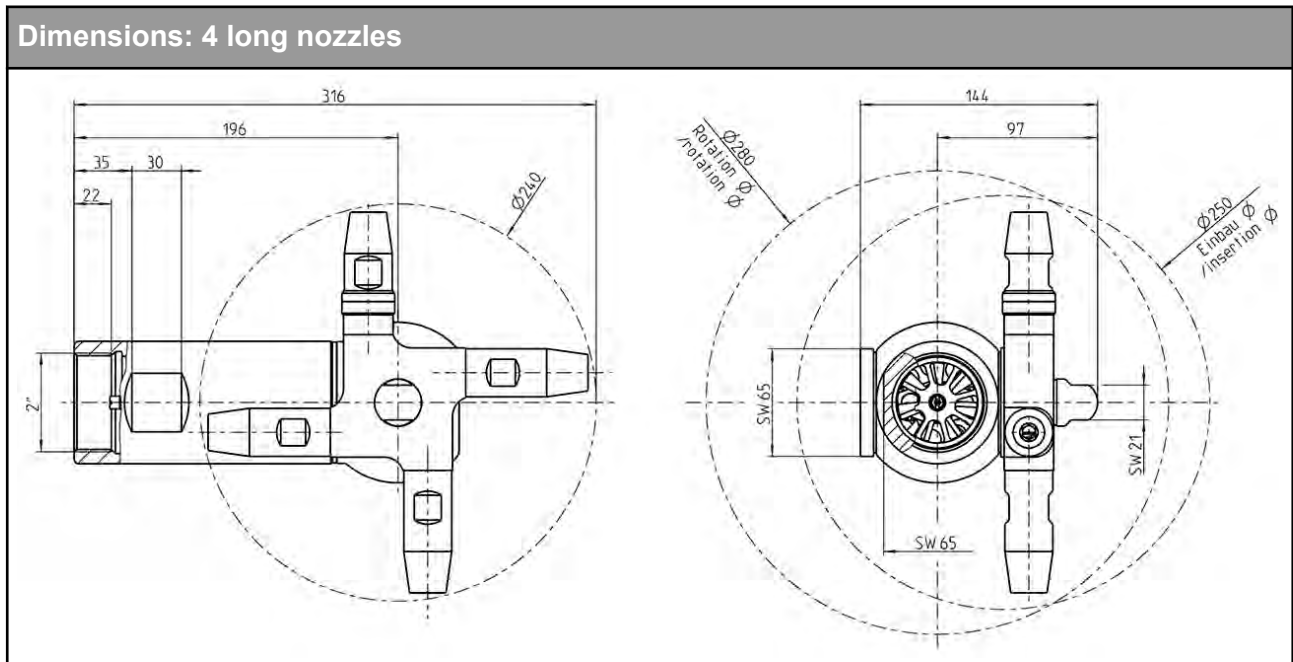

Dimensions: 3 long nozzles

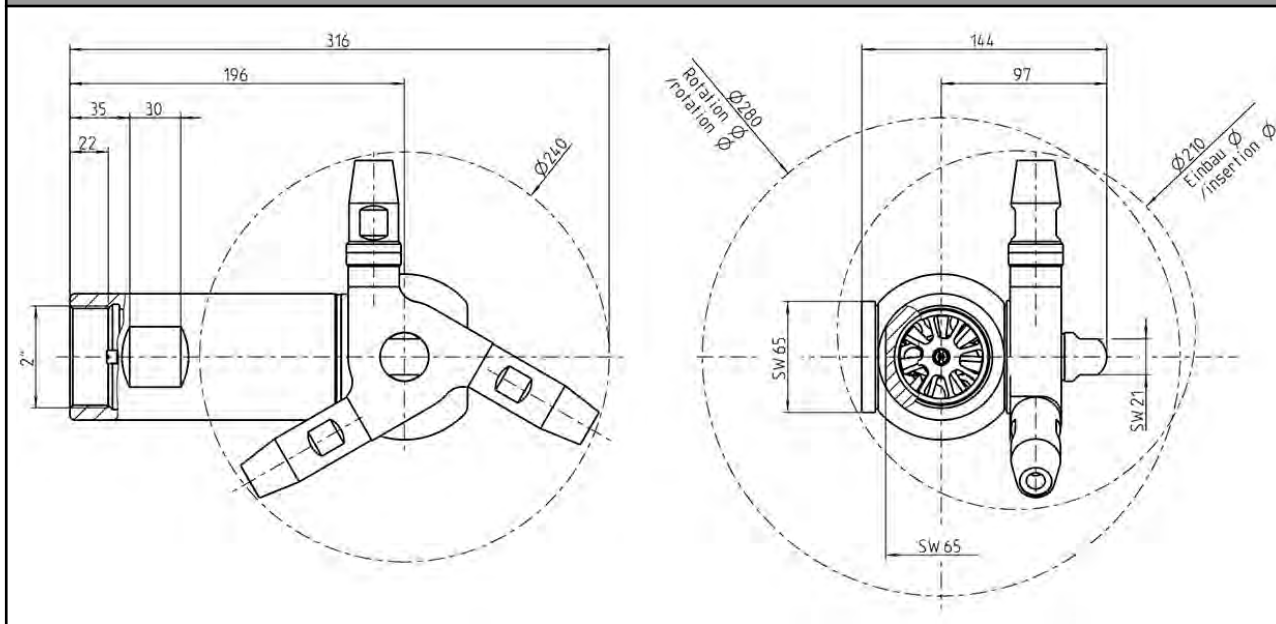

Dimensions: 2 long nozzles with nozzle extension

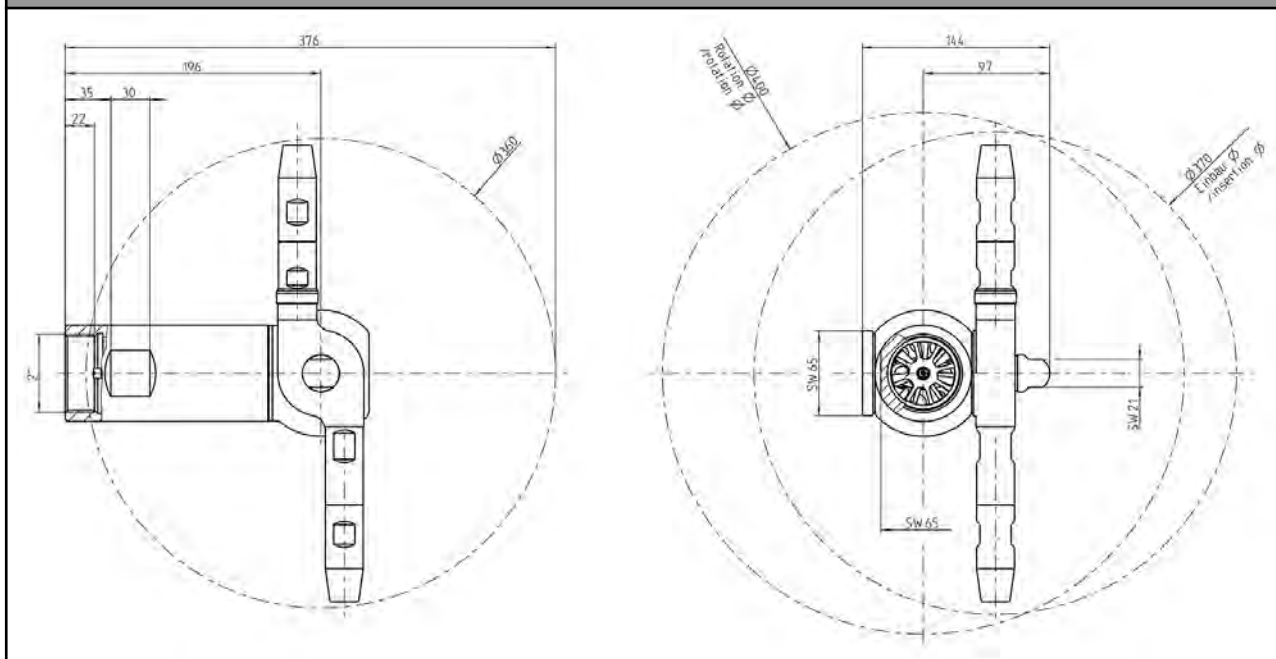

Tank opening

Nozzle carrier	Nozzle length	Min. tank opening
2 and 4	Standard	Ø 250 mm
	Short	Ø 200 mm
	Standard with extension	Ø 370 mm
3	Standard	Ø 210 mm
	Short	Ø 200 mm
	Standard with extension	Ø 320 mm

Technical data

Resistance and permitted operating temperature of the sealing materials

5.4 Resistance and permitted operating temperature of the sealing materials

The resistance of the materials depends on the type and temperature of the medium conveyed. The exposure time can adversely affect the service life of the seals.

The maximum operating temperature is defined by the sealing type and its mechanical load.

Resistance:

- + = good resistance
- o = reduced resistance
- – = no resistance

Sealing resistance / permitted operating temperature - materials				
Medium	Maximum operating temperatures	Material		
		A350	H370	PEEK
Alcohols	Room temperature	+ to 0	+	+
Hydrocarbons		+	+	+
Fats, oils, non-additive		+	+	+
Fuels		+	+	+
Diluted acids		+	+ to 0	+
Strong acids		+	+ to -	+
Diluted acids		+	+	+
Strong alkalis		+	+	+

Sealing resistance / permitted operating temperature - other materials				
Medium	Maximum operating temperatures	Material		
		C-PTFE	EPDM	FKM
Alkalis up to 3%	up to 80 °C (176°F)	+	+	0
Alkalis up to 5%	up to 40 °C (104°F)	+	+	0
Alkalis up to 5%	up to 80 °C (176° F)	+	+	-
Alkalis more than 5%		+	0	-
Inorganic acids up to 3%**	up to 80 °C (176°F)	+	+	+
Inorganic acids up to 5%**	up to 80 °C (176°F)	+	0	+
Inorganic acids up to 5%**	up to 100 °C (212°F)	+	-	+
Water	up to 100 °C (176°F)	+	+	+
Steam	up to 135 °C (275° F)	+	+	0
Steam, approx. 30 min	up to 150 °C (302°F)	+	+	0
Steam, approx. 30 min	up to 160 °C (320°F)	+	-	0
Fuels/hydrocarbons		+	-	+

Sealing resistance / permitted operating temperature - other materials				
Medium	Maximum operating temperatures	Material		
		C-PTFE	EPDM	FKM
Product with a fat content of max. 35%		+	+	+
Product with a fat content of more than 35%		+	-	+
Oils		+	-	+

** Inorganic acids are, e.g. carbonic acid, nitric acid and sulphuric acid

Material	General temperature resistance*
A350	-100...+140°C (-148...+284 °F)
H370	-40...+100°C (-40...+212 °F)
PEEK	-100...+250°C (-148...+482F)
C-PTFE	-40...+260°C (-40...500 °F)
EPDM	-40...+140°C (-40...284 °F)
FKM	-10...+200 °C (+14...+392 °F)

* The general resistance of the material does not correspond to the maximum operating temperature

5.5 Tool

Required tools				
Tool	Component	Size	Item no.	Material Number
Small screwdriver	Circlips	e.g. 0.4 x 2.5	1	
Large screwdriver	Drive shaft	e.g. 1.2 x 8	2	
Open-ended wrench	Static bevel gear	AF 27	3	
Torque wrench 10-60 Nm			4	4660-9000-100
Jaw wrench holding fixture for torque wrench pos. 4	Nozzles (4,5,7,8)	AF 24	5	408-172
	Cap nut (40)	AF 21	6	
Torque wrench 1-5 Nm			7	4660-9000-000
Hexagonal attachment for Torque wrench pos. 7	Set screw (27)	3	8	4660-9062-020
	Cylinder head screw (30)	2.5	9	4660-9042-020

Technical data
Weights

Required tools				
Tool	Component	Size	Item no.	Material Number
Mounting tool	Bearing D 8 (31)	Ø 8	10	4660-9063-012
	Bearing D 14 (32)	Ø 14	11	4660-9063-013
	Bearing D 18 (38)	Ø 18	12	4660-9063-014
	Bearing D 20 (35)	Ø 20	13	4660-9063-015
Suitable grease e.g. Rivolta F.L.G. MD-2	Thread Fits	100g		413-136

5.6 Weights

Nozzle carrier	Nozzle length	Weight [kg]
4	Standard	6.5
	Short	6.1
	Standard with extension	7.2
3	Standard	6.1
	Short	5.9
	Standard with extension	6.7
2	Standard	5.9
	Short	5.7
	Standard with extension	6.2

6 Assembly and installation

6.1 Safety notes

Hazardous situations during installation can be avoided by safety-conscious and proactive behaviour of the personnel.

For installation, the following principles apply:

- Only properly qualified staff is allowed to install, assemble and set the cleaner into operation.
- Ensure that adequate working and traffic areas are available at the place of installation.
- Observe the maximum load-bearing capacity of the installation surface.
- Observe the transport instructions and markings on the part(s) to be transported.
- Remove any nails protruding from transport crates immediately after opening the crate.
- Under no circumstances should anyone stand under a suspended load.
- During assembly, the cleaner's safety devices might not be working effectively.
- Reliably secure sections of the plant which have already been connected against inadvertently being switched on.

6.2 Notes on installation

Observe the following points before installing the cleaner:

- Switch off the power circuit and protect it from unauthorized switch-on.
- Protect the supply pump for CIP medium against unauthorized switch-on.
- Shut off the cleaning medium supply line and secure the line against being opened. There must not be any chemical cleaning medium in the supply line.
- Make sure that there are no foreign objects in the system.
- Clean (rinse) the cleaning medium supply line before connecting the orbital cleaner.
- The electrical installation must be in accordance with the requirements of EN 60079-14 in areas with explosive gas atmosphere and in accordance with the requirements of EN 61241-4 in areas with explosive dust atmosphere.

6.3 Installation

Prerequisite

- We generally recommend that a 500 µm filter/strainer should be installed in the CIP supply line at the tank cleaner to prevent blockage or damage resulting from foreign particles. It is the customer's responsibility to ensure the suitability of the strainer/filter retention rating for this particular application.
- The cleaner must have a suitable pipe connection for this.

- The user must ensure a loss-proof lead connection into the tank. For this, Breconcherry Ltd. offers, among other things, suitable components and a mounting system.

Notice

Danger when screwing the cleaner to the fixed pipe via the rotating (lower) housing

The application of a force to the nozzle carrier or to the rotating (lower) housing leads to damage to the gears inside the cleaner.

- ▶ Screw the static (upper) housing (1) to the pipe (3).

Carry out the following steps:

1. Hold the static (upper) housing (1) and carefully screw it onto the pipe (3) until it is hand-tight.

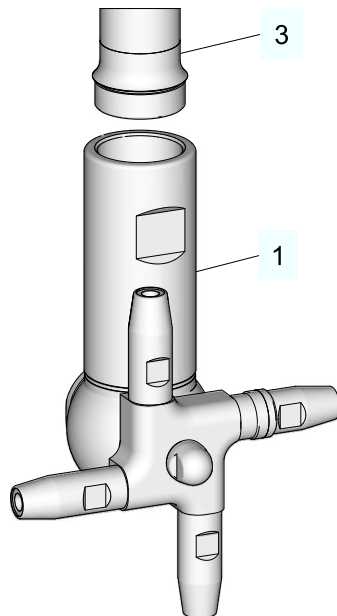

Fig.4

2. Use a strap wrench/adjustable spanner on the static (upper) housing or a suitably sized spanner on the spanner flats provided to tighten the cleaner on the pipe.

→ Done.

6.4 Removing

Remove in reverse sequence of installation.

⚠ Caution!

Hot surface of the cleaner

Danger of burns.

- ▶ Allow the cleaner to cool before removing it.

⚠ Caution!

Hot and aggressive liquids can be discharged from the cleaner.

Danger of injury.

- ▶ Completely drain the cleaner before removing it.

Notice

Danger when unscrewing the cleaner via the lower body

Doing so will cause damage to the gears inside the cleaner or jamming of the mechanism

- ▶ Use the cylindrical upper body as contact point for the tool.

Carry out the following steps:

1. Use a strap wrench/adjustable spanner on the static housing or a suitably sized spanner on the spanner flats provided to unscrew the cleaner from the pipe.
2. Support the rotating housing (2) and carefully unscrew the static (upper) housing (1) by hand until the cleaner comes free from the inlet pipe (3).

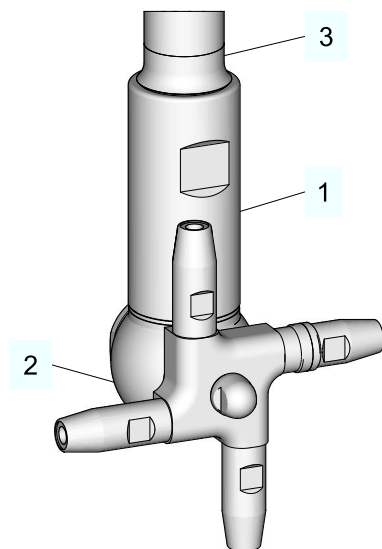

Fig.5

→ Done.

7 Start-up

7.1 Safety notes

Initial commissioning

For initial commissioning, the following principles apply:

- The cleaner must be completely assembled and correctly adjusted. All screw connections must be securely tightened.
- Reliably secure machine parts which have already been connected against inadvertently being switched on.
- After conversion of the cleaner, residual risks must be reassessed.

Commissioning

For commissioning, the following principles apply:

- Only allow properly qualified staff to set the cleaner into operation.
- Make sure that all connections are functioning properly.
- When the cleaner is switched on, the danger zones must be free.
- Remove any liquids that have escaped without leaving residues.

7.2 Commissioning

Prerequisite:

- Avoid water hammers in the supply pipe.



Caution!

Hot and aggressive liquids are discharged from the cleaner!

Risk of injury

- ▶ Make sure nobody stands in the area of action of the nozzles.
- ▶ The cleaner may only be operated in a container intended for this purpose.

Carry out the following steps:

1. Connect the cleaner and set it into operation.
- Done.



Hint!

Noise generated when the cleaning jets hit the tank wall can cause discomfort and stress in the immediate vicinity.

8 Operation and control

8.1 Safety notes

Dangerous situations during operation can be avoided by safety-conscious and proactive behaviour of the personnel.

For operation, the following principles apply:

- Monitor the cleaner during the operation.
- Safety devices must not be changed, removed or taken out of service. Check all safety devices at regular intervals.
- All guards and hoods must be fitted as intended.
- The place of installation of the cleaner must be adequately ventilated at all times.
- Structural alterations of the cleaner are not permitted. Immediately report any changes on the cleaner to the person responsible.
- Always keep danger zones clear. Do not leave any objects in the danger zone. Only allow persons to enter the danger zone when the machine is de-energized.
- Regularly check that all emergency stop devices are working correctly.

8.2 Operating Conditions

The cleaner is driven by the cleaning liquid flowing through it at a suitable pressure and flow rate. It is essential that the cleaner is supplied with cleaning liquid at the correct pressure and flow rate for effective operation. The requirements are specified in the tables below.

The specified pressure is the pressure required at the orbital cleaner and not at the pump.



Hint!

The cleaner may only be operated at a maximum pressure of 10 bar (145 psi). Higher pressures can destroy the cleaner.

Operating flow and pressure conditions orbital cleaner OC 200 - 2 nozzles

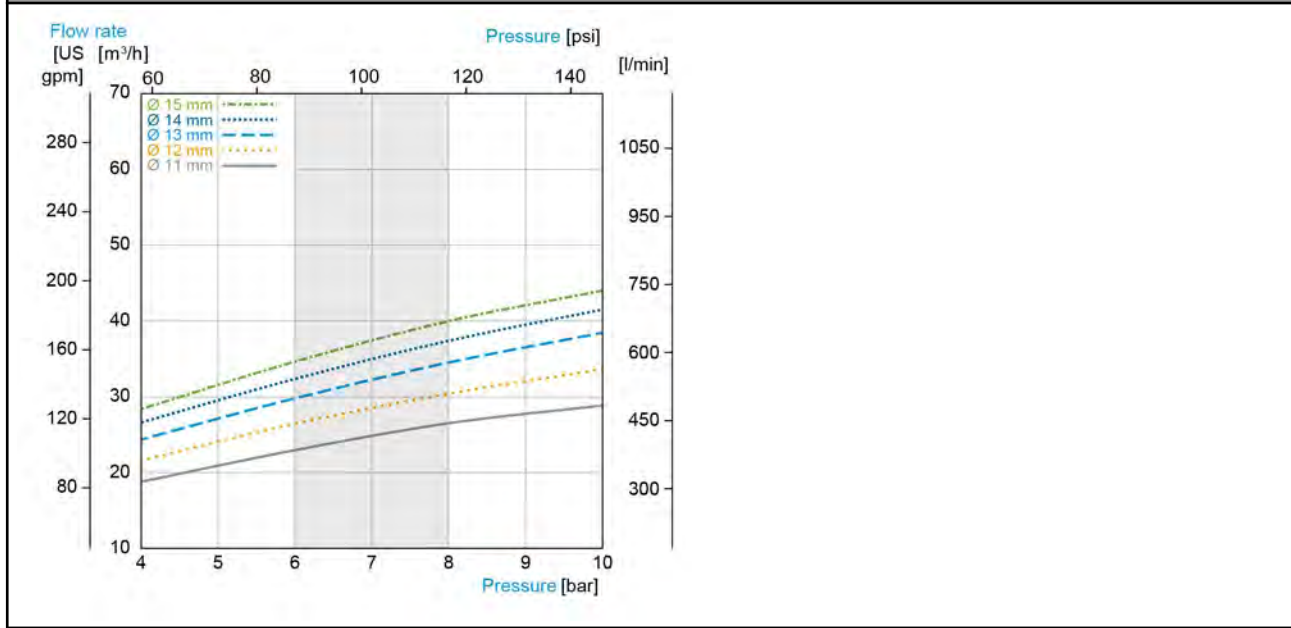

Operating flow and pressure conditions orbital cleaner OC 200 - 3 nozzles

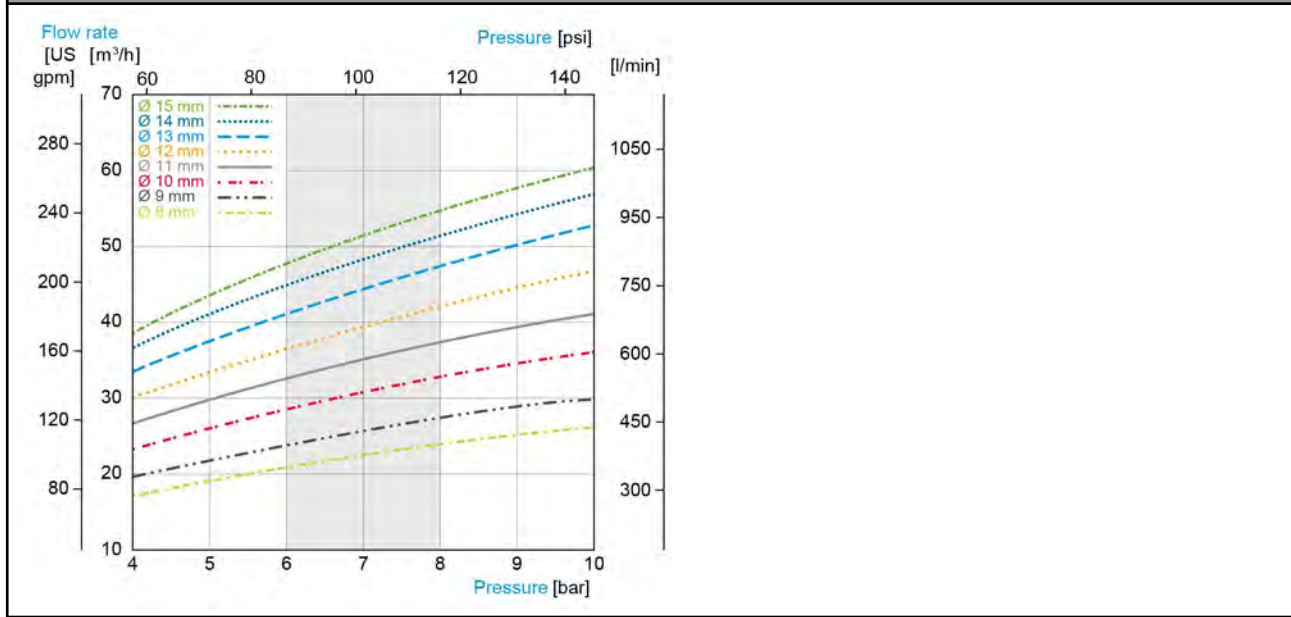

Operating flow and pressure conditions orbital cleaner OC 200 - 4 nozzles

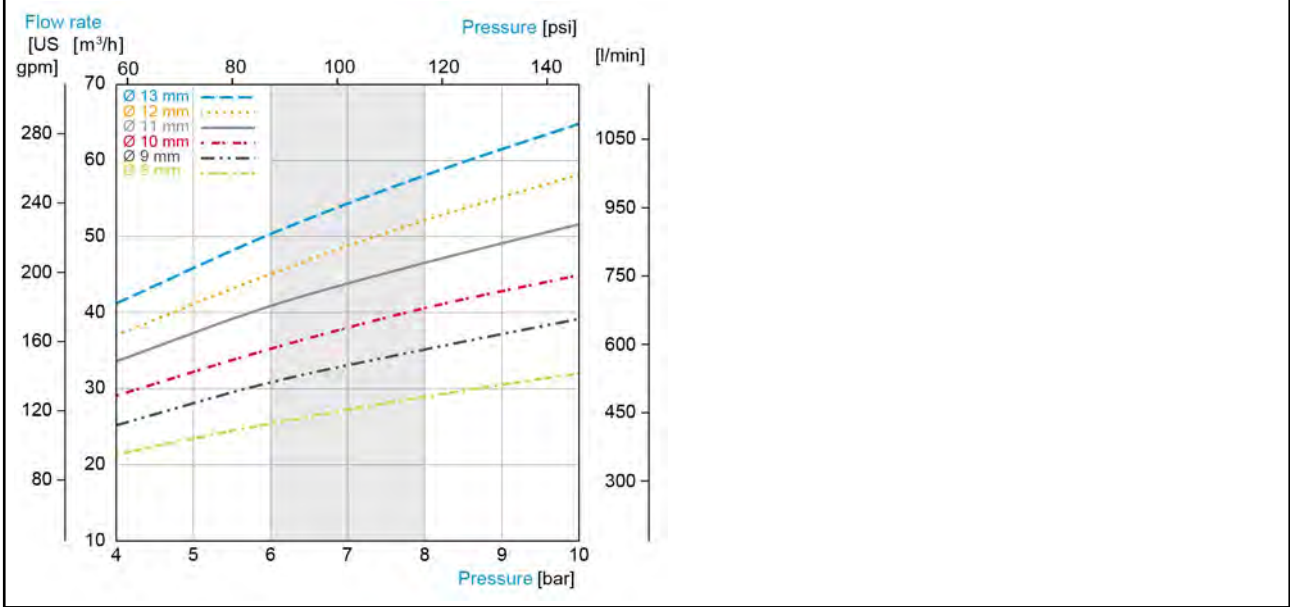

9 Maintenance

9.1 Safety notes

Maintenance and repair

For maintenance and repair, the following principles apply:

- Observe the intervals specified in the maintenance schedule.
- Only allow qualified staff to carry out maintenance or repair work on the cleaner.
- Before starting any maintenance or repair work, the cleaner must be switched off and secured against being switched back on. Work may only be started once any residual energy has been discharged.
- Block access for unauthorized persons. Put up notice signs which draw attention to the maintenance or repair work going on.
- Do not climb on the cleaner. Use suitable access aids and working platforms.
- Wear suitable protective clothing.
- Only use suitable and undamaged tools to carry out maintenance work.
- When replacing parts only use approved, fully functional load lifting devices and lifting accessories which are suitable for the intended purpose.
- Before setting the unit back into operation refit all safety devices as originally provided in the factory. Then check that all safety devices are working correctly.
- Check pipes are firmly secured, also check for leaks and damage.
- Check that all emergency stop devices are working correctly.

Disassembly

For disassembly, the following principles apply:

- Only allow qualified staff to disassemble the cleaner.
- Before starting disassembly, the cleaner must be switched off and secured against being switched back on. Work may only be started once any residual energy has been discharged.
- Disconnect all power and utility lines.
- Markings, e.g. on lines, must not be removed.
- Do not climb on the cleaner. Use suitable access aids and working platforms.
- Mark the lines (if unmarked) prior to disassembly to ensure they are not confused when re-assembling.
- Protect open line ends with blind plugs against ingress of dirt.
- Pack sensitive parts separately.

9.2 Maintenance intervals

The practical maintenance intervals can only be determined by the user since they depend on the operating conditions, for instance:

- type and temperature of the cleaning solution,
- ambient conditions.

Maintenance intervals	
Applications	Maintenance intervals (guideline values)
Inspection	175 hours of operation
Maintenance	500 hours of operation

9.3 Replace stator and impeller

If you only want to replace the impeller so that the cleaner rotates at a different speed, or if you have to replace the impeller because you have changed the nozzle configuration (nozzle carrier and nozzle diameter), you do not need to disassemble the entire cleaner. You can also remove the stator (10) and replace the impeller (11) from above:

1. Remove the circlip (12) from the static housing using a small screwdriver.

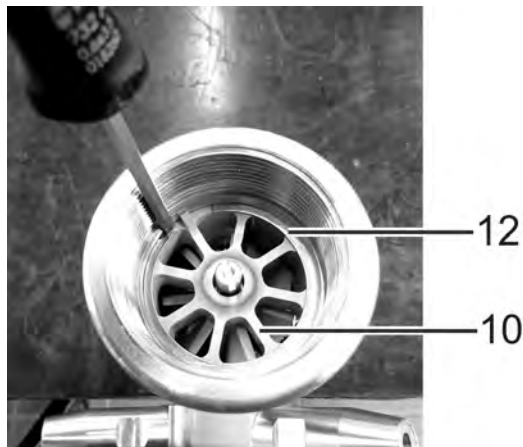

Fig.6

2. Lift out the stator (10) upwards.

! Residue build up of the cleaner may make the stator difficult to remove. In this case please use pliers to help you.

Maintenance

Replace stator and impeller



Fig.7

3. Remove the drive shaft (16) with the impeller (11). No tool is required for this, the parts should easily lift out.



Fig.8



Fig.9

4. Pull off the impeller (11) by hand.



Fig.10

5. Push a new impeller (11) onto the drive shaft so that the spanner flats of the drive shaft are correctly in the impeller.

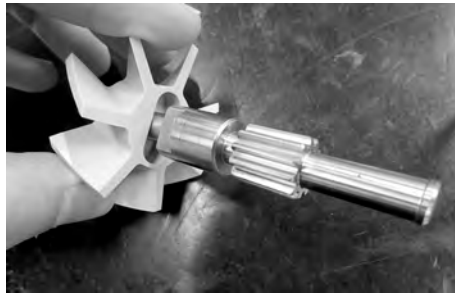

Fig.11



Fig.12

6. Push the drive shaft (16) with impeller (11) into the planet gear (13) until the teeth of the drive shaft engage correctly with the teeth of the planet gears.
7. Insert the stator (10) into the static housing (1).



Fig.13

8. Thread the circlip (12) into the groove and press into position
! The tip at the stator must be in the open part of the circlip.



Fig.14



Fig.15

9. Check that the planet gear can be turned easily. To do this, turn the drive shaft (16) using a screwdriver.

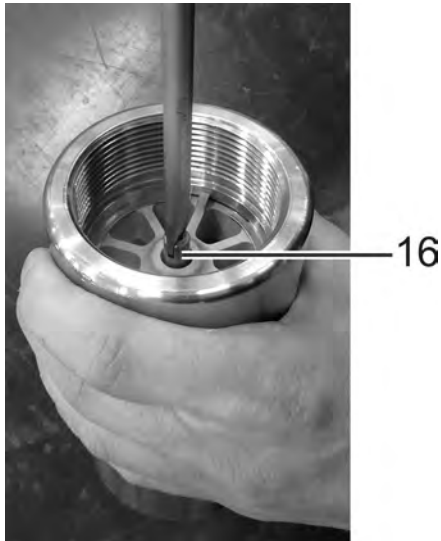

Fig.16

10. Check if the planet gear has axial clearance. To do this, move the drive shaft slightly up and down.

9.4 Disassembly

9.4.1 Dismantling the rotating (lower) housing

Requirement:

- The cleaner must be removed, cooled and completely drained.



Hint!

The plastics bearings are pressed in. After removal, the bearings cannot be used again. New bearings must be used.

Remove individual parts from the rotating housing (2)

Carry out the following steps:

1. Clamp the cleaner on the spanner flat of the shaft (24) in a vice.



Fig.17

2. Remove cap nut (40) and remove the O-ring (42).



Fig.18



Fig.19

3. Pull off the nozzle carrier (3) by hand.



Fig.20

! Residue build up of the cleaner may make the nozzle carrier difficult to remove. Hold the cleaner in your hand as shown. Loosen the nozzle carrier with a blow on the shaft.



Fig.21

4. Remove wedge fix-lock washers (41) and seal ring (37).



Fig.22

5. Lift the cleaner off the clamped shaft.



Fig.23

6. Remove the second seal ring (37).



Fig.24

7. Loosen the shaft (24) in the vice.



Fig.25

8. If necessary, as not urgently required for maintenance: Disassemble all nozzles (4, 5, 7, 8). To do this, clamp the nozzle carrier in a vice with protective jaws and unscrew the nozzles.

! Do not remove the pressed-in stream straighteners from the nozzles.

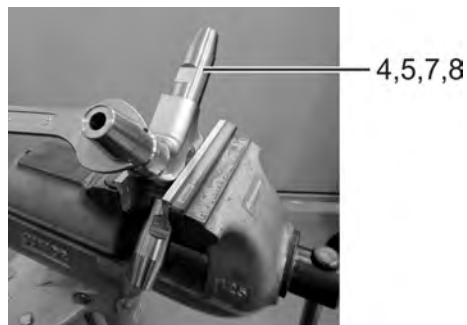

Fig.26



Fig.27



Fig.28

9. If necessary, as not urgently required for maintenance: Clamp the shaft in a vice and loosen the circlip (26) from the shaft using a small screwdriver and pull off the bevel gear (23) by hand.

! Make sure that the feather key (25) is not lost.

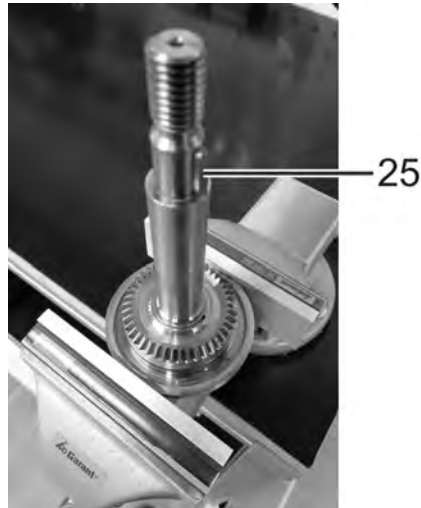

Fig.29



Fig.30

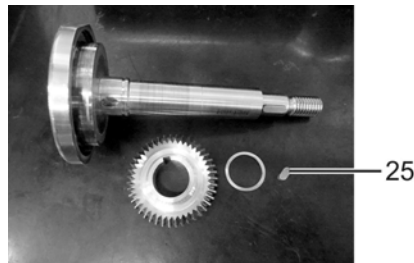

Fig.31

→ Done.

9.4.2 Separate static (upper) and rotating (lower) housing

Carry out the following steps:

1. Undo the cylinder head screws (30). Subsequently, remove the cylinder head screws (30) wedge fix-lock washers (29) and the keep plate (28). This procedure must be carried out on both sides.

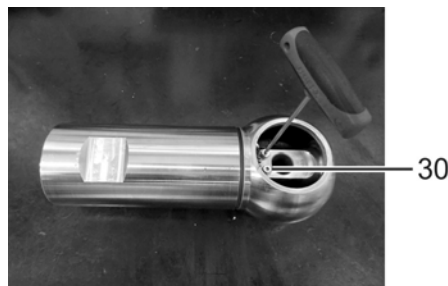

Fig.32



Fig.33

2. Remove the set screw (27). This procedure must be carried out on both sides.



Fig.34



Fig.35

3. Clamp the rotating housing (2) in a vice with protective jaws.

Notice

The driven gear can be destroyed.

The two set screws (27) secure the lower housing so that it does not become loose during operation.

► If the two set screws (27) are not dismantled, the lower end of the driven gear will be sheared off.

With a large adjustable spanner unscrew the static housing (1) anti-clockwise (right-hand thread) until the static housing separates from the rotating housing.



Fig.36

4. Static and rotating housing are separated.



Fig.37

5. Remove the bearing (38) with the mounting tool (18) and soft-faced hammer from the rotating housing (2) and dispose of it.



Fig.38



Fig.39

→ Done.

9.4.3 Remove individual parts from static (upper) housing (1)

Carry out the following steps:

1. Clamp static housing (1) into vice with protective jaws in the area of the spanner flats. Carefully pry open and remove the circlip (30) with a small screwdriver.



Fig.40



Fig.41

2. Unscrew the bevel gear (22) in an anti-clockwise manner using a jaw wrench (AF 27).



Fig.42

3. Remove the bearing (35) with the mounting tool (13) and soft-faced hammer from the bevel gear (22) and dispose of it.



Fig.43



Fig.44

4. Remove the drive wheel (20) from the static housing. No tool is required for this, it should easily lift out.

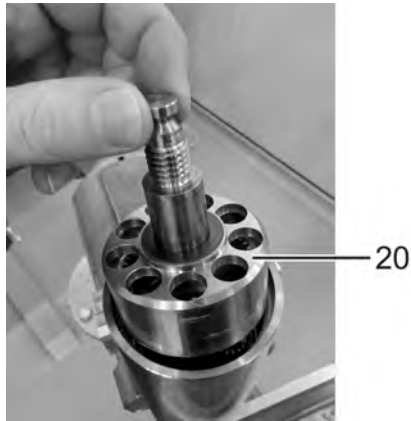

Fig.45

5. Clamp the driven gear in a vice with protective jaws. Remove the bearing (34) from the driven gear (20) using a small screwdriver.
! To do this, lever out the bearing.



Fig.46



Fig.47

6. Remove the bearing (33) from the static housing (1) by hand.

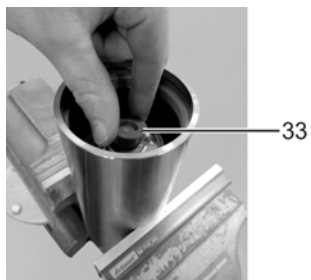

Fig.48

7. Remove the planet gear carriers (13) from the static housing (1). No tool is required for this, the parts should easily lift out.

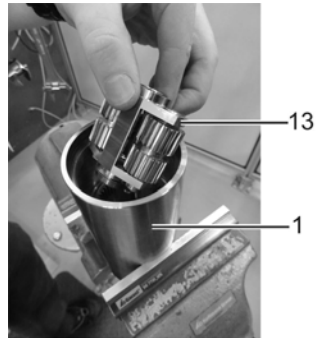

Fig.49

8. Remove the drive shaft (16). No tool is required for this, the parts should easily lift out. The impeller may slip off the shaft. In case the impeller stays on the shaft, remove it later on.

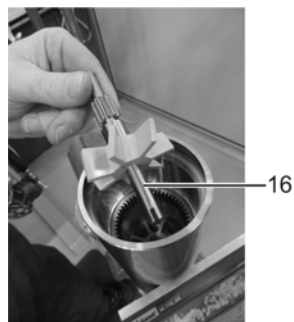

Fig.50

9. Remove the circlip (12) from the static housing using a small screwdriver.

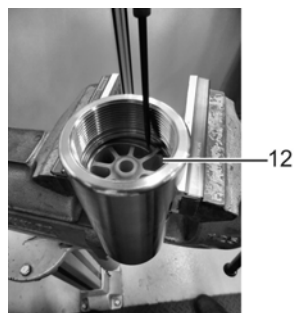

Fig.51

10. Lift out the stator (10) upwards.

! Residue build up of the cleaner may make the stator difficult to remove. In this case please use pliers to help you.



Fig.52

11. Remove the bearing (31) with the mounting tool (10) and soft-faced hammer from the stator (10) and dispose of it.

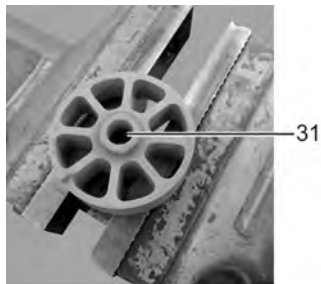

Fig.53



Fig.54

- ! The internal gear (17) is pressed in the housing (1) and remains in the housing.
→ The individual parts are removed from the static housing.



Fig.55

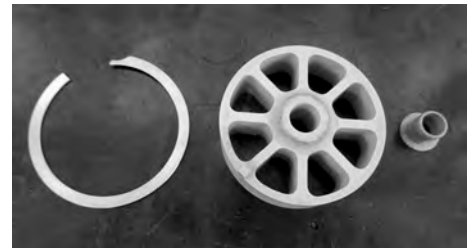

Fig.56

9.4.4 Disassembly of the planet gear

Carry out the following steps:

1. Clamp the planet gear in a vice with protective jaws.



Fig.57

2. Carefully pry open and remove the circlip (14) with a small screwdriver.



Fig.58

3. Pull out the spindles (15) and remove the planet gears (18, 19).

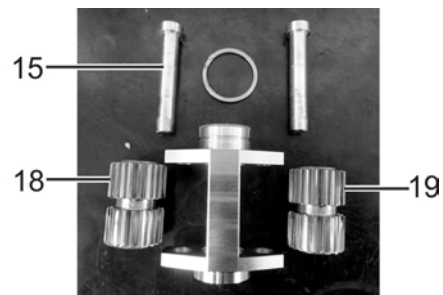

Fig.59

4. Place the planet gear carriers onto the vice.
5. Remove the bearing (31) from the planet gear carrier (10) using the mounting tool (Ø 8) and dispose of it.

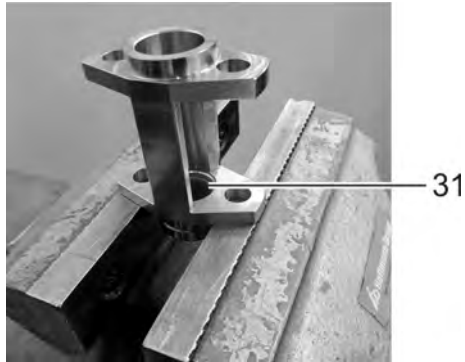

Fig.60

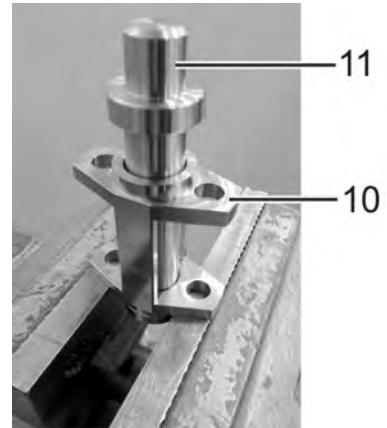

Fig.61

6. Place the planet wheel onto the vice. Remove the bearing (31) from the planets using the mounting tool (11). This has to be done on both planets.



Fig.62



Fig.63

- The planet gear carrier is disassembled.
- The cleaner is now disassembled.

9.5 Installation

9.5.1 Torques of the cleaner components

When mounting the components of the cleaner, follow the torques specified in the table.

Torques			
Item no.	Designation		[Nm]
4, 5, 7	Nozzle	M 24 x 1.5	40
27	Set screw	M 6	5

Torques			
Item no.	Designation		[Nm]
30	Cheese head screw	M 4	3.5
40	Cap nut	M 12	35

9.5.2 Installing the drive shaft assembly

Carry out the following steps:

1. Press the bearing (31) into the flat side of the stator (10) using the mounting tool (13). Use a soft-faced hammer for pressing in the bearing.

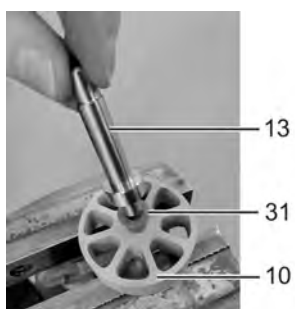

Fig.64

2. Insert the stator (10) into the static housing (1).

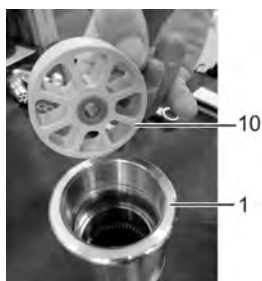

Fig.65

3. Thread the retaining ring (12) into the groove and press into position
! The tip at the stator must be in the open part of the circlip.



Fig.66



Fig.67

4. Push the impeller (11) onto the drive shaft so that the spanner flats of the drive shaft are correctly in the impeller.



Fig.68

5. Push the drive shaft (16) into the middle bore of the stator.



Fig.69

→ The drive shaft is mounted.

9.5.3 Assemble the planetary gear

Carry out the following steps:

1. Press the bearing (23) into the “snap ring end” of the planet gear carrier using the mounting tool (11).
! Pay attention that the flat sides of the bushings are seated directly above the carrier unit.



Fig.70

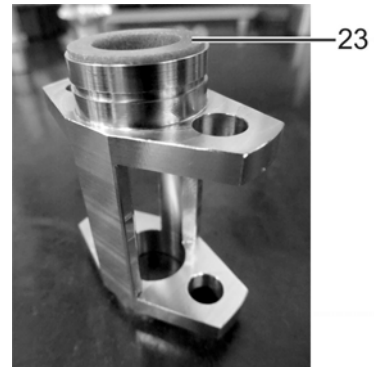

Fig.71

2. Press the bearing (31) into the planet gears (18 and 19) using the mounting tool (10).

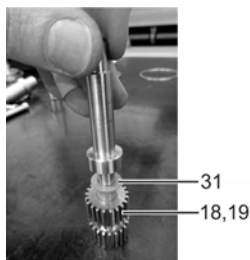

Fig.72

3. Insert the planet gears (18 and 19) into the planet gear carrier (13).
4. Mount the planet gears (18 and 19) and spindles (15) so that the flat sides of the spindle heads are fitted to the top of the planet gear carrier.



Fig.73

5. Insert the retaining ring (36) into the groove provided.

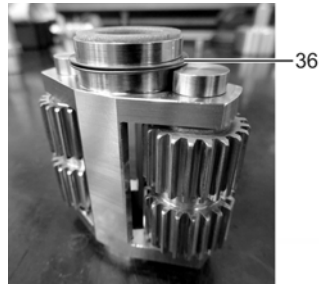

Fig.74

6. Slide the planet gear over the end of the drive shaft and replace it in the static housing. Insert the end with the bushings first. The assembly should be easily inserted.

! Make sure that the planet gears engage with the internal gear in the static housing.



Fig.75



Fig.76

! The planet gear carrier should be seated loosely and be able to be turned freely by hand. Otherwise remove the planet gear carrier again and re-insert it.

7. Insert the bearing (33) into the planet gear carrier (13).

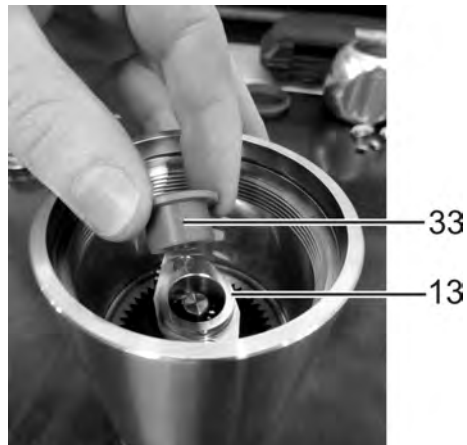

Fig.77



Fig.78

8. Place the bearing (34) into the groove of the driven gear (20).

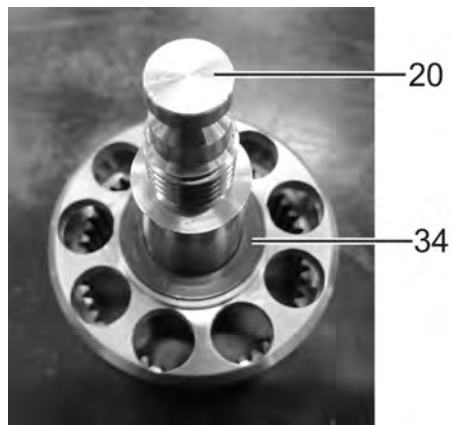

Fig.79

9. Push the driven gear (20) into the static housing over the planet gear carrier. The teeth of the driven gear engage in the teeth of the planet gears and are thus correctly seated in the bearing (33).

! The drive wheel unit is now fixed and can no longer be turned freely by hand.



Fig.80

→ The planetary gear is assembled.

9.5.4 Installation of the bevel gear in the static (upper) body

Carry out the following steps:

1. Place the bevel gear (22) with the teeth on a soft surface so that they are not damaged when the bearing is hammered in.
2. Using a soft-faced hammer and the mounting tool (13) hammer the plain bearing (35) into the bevel gear (22).



Fig.81



Fig.82



Fig.83

3. Slightly grease the thread on the bevel gear (22), e.g. using Rivolta F.L.G. MD-2.
4. Push the assembly with the end of the bearing first over the driven gear. As soon as the two screw threads are slightly in contact, carefully tighten clockwise.
5. Clamp the static housing at the spanner flats in a vice with protective jaws. Tighten the bevel gear (22) hand-tight using a jaw wrench (AF 27).



Fig.84

6. Thread the retaining ring (21) into the groove and press into position.



Fig.85



Fig.86

→ The bevel gear is installed in the static housing.

9.5.5 Assembly static (upper) and rotating (lower) housing

Requirement:

- Before assembly check that the planet gear can be turned easily. To do this, turn the drive shaft (16) using a screwdriver.

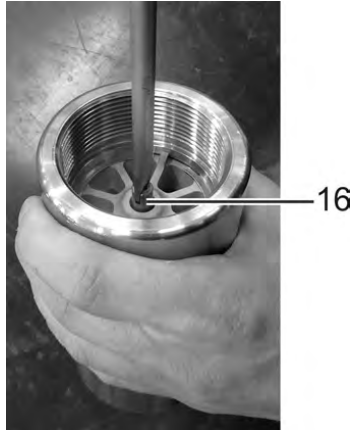

Fig.87

- Subsequently check if the planet gear has axial clearance. To do this, move the drive shaft slightly up and down. If there is no axial clearance, it may be that the bearings have not been pressed in correctly.

Carry out the following steps:

1. Place the bearing (38), with the small chamfer first, into the large bore in the centre of the rotating housing. Subsequently, press in with the mounting tool (12) and a soft-faced hammer until the stop.



Fig.88

2. Place seal ring T (36) in the groove on the front side of the static housing (1).



Fig.89

3. Engage the spindle protruding from the bevel gear in the static housing into the corresponding threaded hole in the rotating housing (2). Tighten hand-tight in a clockwise fashion.

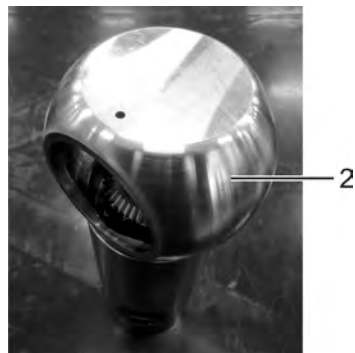

Fig.90

4. Clamp the rotating housing in a vice with padded jaws and attach an adjustable wrench to the static housing (1). Gently tighten the cleaner. Due to the large tool, a high torque is transmitted to the cleaner.

! Attention. Unlike with other cleaners, this is not a left-hand thread. It is a right-hand thread. The cleaner must be tightened in clockwise direction.



Fig.91

5. Remove from the vice and insert the set screw (27) into the middle upper bore in the rotating housing. Tighten with an Allen key (AF 3). Torque, see Section 9.5.1, Page 46.



Fig.92

Carry out the same step again on the opposite side.

6. Insert the keep plate (28) and screw in the two cylinder head screws (30) with the wedge fix-lock washers (29). The wedge fix-lock washers must be installed as a pair. To do this, place both disks one above the other so that the larger teeth lie on top of each other. Tighten with an Allen key (AF 3). Torque, see Section 9.5.1, Page 46.

! Maintain the torque of the cylinder head screws. If the torque is too low, the screws can loosen themselves and if the torque is too high, the screws can no longer be removed professionally.



Fig.93



Fig.94

Carry out the same step again on the opposite side.

→ Static and rotating housing are assembled.

9.5.6 Mounting the nozzle carrier

Mounting the nozzles

Carry out the following steps:

1. Clamp the nozzle carrier in the vice.

2. Push the nozzle sleeve over the self-cleaning nozzle and mount hand-tight.
! Make sure that the hole of the nozzle sleeve points towards the opening of the nozzle carrier.



Fig.95



Fig.96

3. Screw the remaining nozzles hand-tight into the nozzle carrier.
4. Tighten the nozzles with the prescribed torque, see Section 9.5.1, Page 46.



Fig.97

5. inserting feather key (25 and 39) into the shaft (24).



Fig.98



Fig.99

6. Push the bevel gear (23) over the shaft.



Fig.100

7. Mount the circlip (26).



Fig.101

8. Clamp the shaft (24) at the AF in a vice and inset the seal ring (37) into the shaft groove.



Fig.102

9. Push the mounted cleaner over the shaft until the bevel gears engage with each other properly.



Fig.103

10. Insert seal ring (37) into the housing (2).



Fig.104

11. Lightly grease the shaft in the area of the feather key.
Slide nozzle carrier over the shaft.



Fig.105

12. Insert wedge fix-lock washers into the groove of the nozzle carrier. The wedge fix-lock washers must be installed as a pair. To do this, place both disks one above the other so that the larger teeth lie on top of each other.



Fig.106

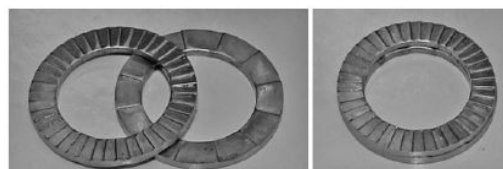

Fig.107

13. Insert the O-ring (42) into cap nut (40).



Fig.108

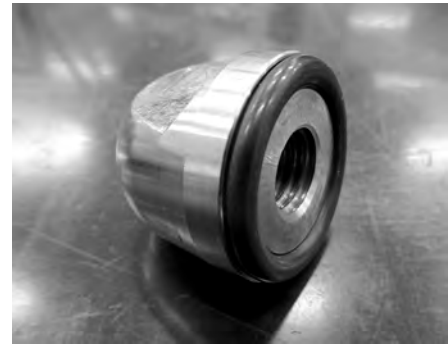

Fig.109

14. Fit cap nut (40) with torque, see Section 9.5.1, Page 46



Fig.110

- The nozzle carrier is installed.
- The cleaner is assembled again.

9.5.7 Check the assembly

Check if the orbital cleaner has been installed correctly.

Carry out the following steps:

1. Turn the drive shaft with a flat-blade screwdriver.



Fig.111

→ When properly installed, the drive shaft should rotate freely, without resistance or snagging.

If resistance is detected, the planetary gears are likely to have been misaligned during assembly.

Do not use the cleaner until it has been dismantled and reinstalled with properly aligned wheels.

2. Now test the cleaner under suitable conditions.

→ The installation is now tested.

10 Alarms

10.1 Malfunctions and remedies

In the event of malfunctions immediately deactivate the cleaner and secure it against inadvertent reactivation. Malfunctions may only be remedied by qualified staff, who must observe the safety instructions.

11 Decommissioning

11.1 Safety notes

For shutting down, the following principles apply:

- For longer periods of standstill, observe the storage conditions, see Chapter 4, Page 16.

11.2 Disposal

11.2.1 General notes

Dispose of the cleaner in an environmentally friendly manner. Observe the statutory waste disposal regulations applicable at the place of installation.

Disassemble the cleaner according to the disassembly instructions and sort the materials according to the spare parts list.

12 Spare parts list - orbital cleaner OC200

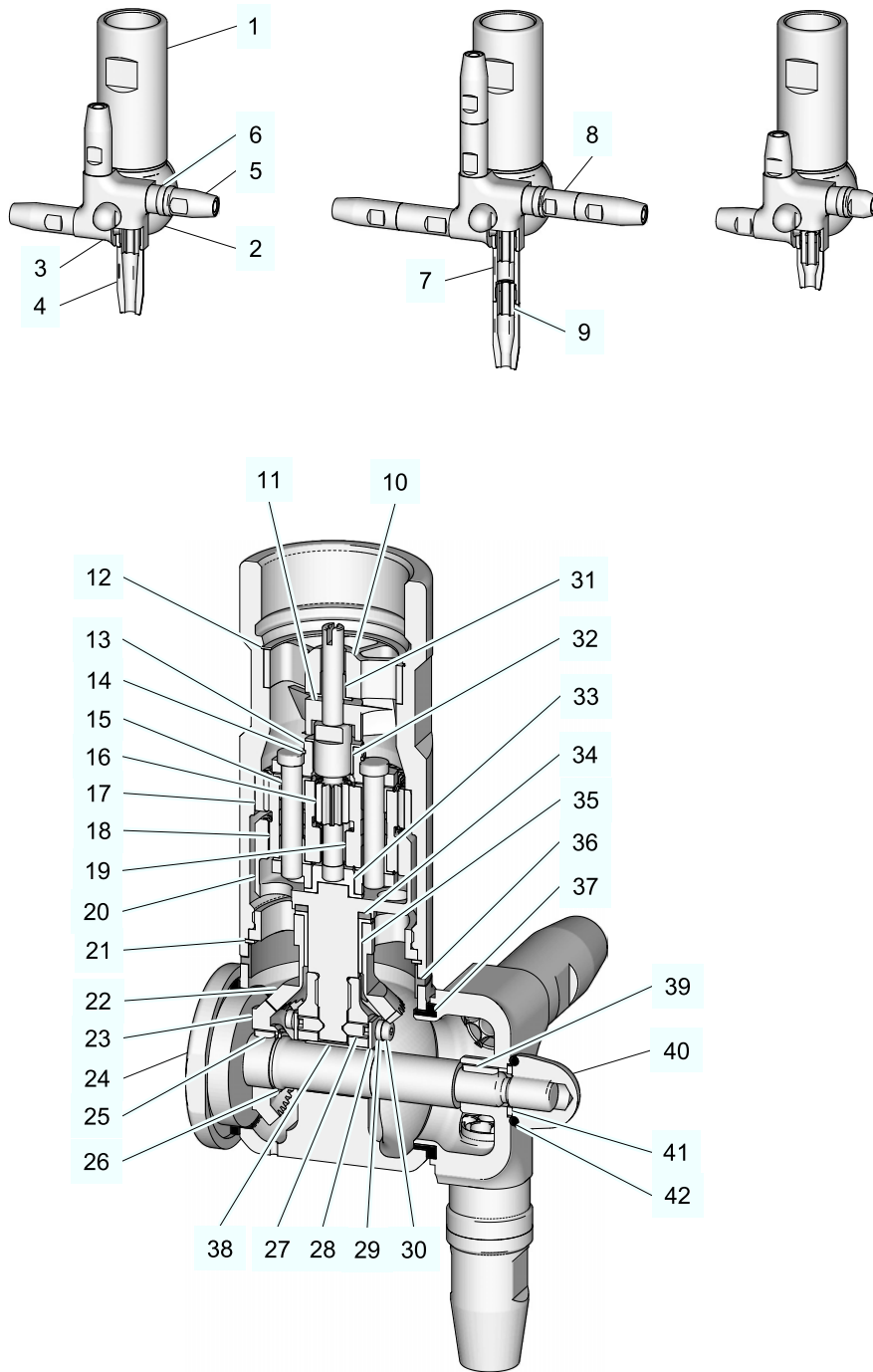

Fig.112

Item	Designation	Material	Material no.
1	Static housing OC2 2"BSP	316L/1.4404	4660-0662-020
1	Static housing OC2 2"NPT	316L/1.4404	4660-0662-021
2	Rotating housing OC2	316L/1.4404	4660-8229-130
3	Nozzle carrier OC2 3N	316L/1.4404	4660-0471-030
3	Nozzle carrier OC2 4N	316L/1.4404	4660-0471-032
3	Nozzle carrier OC2 2N	316L/1.4404	4660-0471-031
4	Nozzle OC2 D 8	316L/1.4404	4660-0480-008
4	Nozzle OC2 D 9	316L/1.4404	4660-0480-009
4	Nozzle OC2 D 10	316L/1.4404	4660-0480-010
4	Nozzle OC2 D 11	316L/1.4404	4660-0480-011
4	Nozzle OC2 D 12	316L/1.4404	4660-0480-022
4	Nozzle OC2 D 13	316L/1.4404	4660-0480-013
4	Nozzle OC2 D 14	316L/1.4404	4660-0480-024
4	Nozzle OC2 D 15	316L/1.4404	4660-0480-015
4	Nozzle OC2 D 8 short	316L/1.4404	4660-0480-108
4	Nozzle OC2 D 9 short	316L/1.4404	4660-0480-109
4	Nozzle OC2 D 10 short	316L/1.4404	4660-0480-110
4	Nozzle OC2 D 11 short	316L/1.4404	4660-0480-111
4	Nozzle OC2 D 12 short	316L/1.4404	4660-0480-112
4	Nozzle OC2 D 13 short	316L/1.4404	4660-0480-113
4	Nozzle OC2 D 14 short	316L/1.4404	4660-0480-114
4	Nozzle OC2 D 15 short	316L/1.4404	4660-0480-115
5	Nozzle OC2 D 8 bow	316L/1.4404	4660-0412-049
5	Nozzle OC2 D 9 bow	316L/1.4404	4660-0412-050
5	Nozzle OC2 D 10 bow	316L/1.4404	4660-0412-051
5	Nozzle OC2 D 11 bow	316L/1.4404	4660-0412-052
5	Nozzle OC2 D 12 bow	316L/1.4404	4660-0412-053
5	Nozzle OC2 D 13 bow	316L/1.4404	4660-0412-054
5	Nozzle OC2 D 15 bow	316L/1.4404	4660-0412-055
5	Nozzle OC2 D 15 bow	316L/1.4404	4660-0412-056
5	Nozzle OC2 D 8 bow short	316L/1.4404	4660-0412-064
5	Nozzle OC2 D 9 bow short	316L/1.4404	4660-0412-057
5	Nozzle OC2 D 10 bow short	316L/1.4404	4660-0412-058
5	Nozzle OC2 D 11 bow short	316L/1.4404	4660-0412-059
5	Nozzle OC2 D 12 bow short	316L/1.4404	4660-0412-060
5	Nozzle OC2 D 13 bow short	316L/1.4404	4660-0412-061
5	Nozzle OC2 D 14 bow short	316L/1.4404	4660-0412-062
5	Nozzle OC2 D 15 bow short	316L/1.4404	4660-0412-063
6	Nozzle sleeve OC2	316L/1.4404	4660-0422-001
7	Nozzle extension	316L/1.4404	4660-0480-102
8	Nozzle extension bow	316L/1.4404	4660-0480-103
9	Stream straightener	PEEK	4660-0682-011
10	Stator OC2 0°	PEEK	4660-0623-004

Spare parts list - orbital cleaner OC200

Item	Designation	Material	Material no.
11	Impeller OC2 7bld 15°	PEEK	4660-8211-016
11	Impeller OC2 7bld 20°	PEEK	4660-8211-015
11	Impeller OC2 7bld 25°	PEEK	4660-8211-014
11	Impeller OC2 7bld 30°	PEEK	4660-8211-013
11	Impeller OC2 7bld 35°	PEEK	4660-8211-012
11	Impeller OC2 7bld 40°	PEEK	4660-8211-011
11	Impeller OC2 7bld 45°	PEEK	4660-8211-017
12 *	Retaining ring	316	4660-0643-000
13	Planet gear carrier OC2	316L/1.4404	4660-8260-701
14 *	Retaining ring	316	4660-8242-011
15	Spindle OC2	316L/1.4404	4660-8282-030
16	Drive shaft OC2	316L/1.4404	4660-4221-035
17	Internal gear OC2	316L/1.4404	4660-8290-031
18	Planet gear odd OC2	316L/1.4404	4660-0475-023
19	Planet gear even OC2	316L/1.4404	4660-0465-023
20	Driven gear OC2	316L/1.4404	4660-0436-025
21 *	Retaining ring	316	4660-8242-014
22	Bevel gear sta OC2	316L/1.4404	4660-0426-020
23	Bevel gear rot OC2	316L/1.4404	4660-0416-020
24	Shaft OC2	316L/1.4404	4660-0613-040
25	Feather key	1.4571	4660-8261-030
26	Retaining ring	316	4660-8242-013
27 *	Set screw	A4	4660-8265-013
28	Keep plate OC2	316L/1.4404	4660-8240-011
29 *	Wedge lock-fix washer M4	1.4547	4660-5810-016
30 *	Cheese head screw	A4	902-142
31 *	Plain bearing	IGLIDUR-H370	704-085
31 *	Plain bearing	IGLIDUR-A350	704-092
32 *	Plain bearing	IGLIDUR-H370	704-083
32 *	Plain bearing	IGLIDUR-A350	704-093
33 *	Bearing OC2	IGLIDUR-A350	4660-0551-039
33 *	Bearing OC2	C-PTFE	4660-0551-040
34 *	Disk OC2	C-PTFE	4660-6230-031
35 *	Plain bearing	IGLIDUR-H370	704-082
35 *	Plain bearing	IGLIDUR-A350	704-094
36 *	Seal ring OC2	C-PTFE	4660-4210-058
37 *	Seal ring OC2	C-PTFE	4660-4210-059
38 *	Plain bearing	IGLIDUR-H370	704-091
38 *	Plain bearing	IGLIDUR-A350	704-095
39 *	Feather key	A4	4660-8261-040
40	Cap nut OC2	316L/1.4404	4660-0613-013
41 *	Wedge lock-fix washer M12	1.4547	4660-5810-013
42 *	O-ring	EPDM	930-524

Item	Designation	Material	Material no.
42 *	O-ring	FKM	930-1032
Parts marked with * are included in the wear sets.			

Wear sets		
Material no.	Designation	Comments
4660-4981-000	Wear part set OC200 A350/EPDM	EU10/2011, FDA
4660-4981-001	Wear part set OC200 A350/ FKM	EU10/2011, FDA
4660-4981-002	Wear part set OC200 H370/EPDM	
4660-4981-003	Wear part set OC200 H370/ FKM	

Accessories		
Material no.	Designation	Comments
254-000826 *	Protecting cage OC 200	G2" connecting thread
705-163 *	Welding nipple G2"/DN50	316L (1.4404)
705-164 *	Welding nipple G2"/ 2" IPS	316L (1.4404)
705-165 *	Welding nipple G2"/ 2" OD	316L (1.4404)
705-166	Welding nipple G2"/ 1.5" F	316L (1.4404)
705-167	Welding nipple G2"/ 1.5" M	316L (1.4404)
705-168	Welding nipple NPT 2"/ 1.5" NPT	316L (1.4404)
930-560	O-ring	EPDM
930-572	O-ring	FKM
* If used, an O-ring is also required		

13 Appendix

13.1 Lists

13.1.1 Abbreviations and terms

Abbreviation	Explanation
ATEX	ATEX is a widely used synonym for the European Union ATEX directives. The designation ATEX is derived from the abbreviation of the French ATmosphère EXplosive.
BS	British Standard
bar	Unit of measurement of pressure [bar] All pressure data expressed in [bar/psi] is assumed to be gauge pressure [barg/psig] unless explicitly specified otherwise.
BSP	British Standard Pipe Thread
approx.	approximately
°C	Unit of measurement of temperature [degree Celsius]
C-PTFE	Carbonated polytetrafluoroethylene
DN	DIN nominal width
DIN	German standard issued by DIN (Deutsches Institut für Normung e.V., German Institute for Standardization)
EN	European Standard
°F	Unit of measurement of temperature [degree Fahrenheit]
h	Unit of measurement of time [hour]
ISO	International Standard of the International Organization for Standardization
kg	Unit of measurement of weight [kilogram]
l	Unit of measurement of volume [litre]
min.	minimum
max.	maximum
mm	Unit of measurement of length [millimetre]
mm	Unit of measurement of length [micrometre]
M	Metric
NPT	National Pipe Thread
Nm	Unit of measurement of work [newton metre] SPECIFICATION FOR THE TORQUE: 1 Nm = 0.737 lbft Pound-Force (lb) + Feet (ft)
PA	Polyamide
PEEK	Polyether ether ketone

Abbreviation	Explanation
PTFE	Polytetrafluoroethylene
psi	Anglo-American unit of measurement for pressure [pound-force per square inch] All pressure data expressed in [bar/psi] is assumed to be gauge pressure [barg/psig] unless explicitly specified otherwise.
AF	Indicates the size of spanners [width across flats]
Inch	Unit of measurement of length in the Anglo-American language area
Inch OD	Tube measurement according to British Standard (BS), outside diameter
Inch IPS	American pipe measurement, iron pipe size



Breconcherry Ltd

Westfalia House, Old Wolverton Road, Milton Keynes, MK12 5PY, United Kingdom
Tel.: +44 (0)1531 632476, Fax: +44 (0)1531 633839
info@breconcherry.com, <http://www.breconcherry.com>